

Real-time Human Motion Analysis and Grasping Force using the OptiTrack System and Flexi-force Sensor

N. F. Elya Saidon^{1*}, Chikamune Wada², Siti A. Ahmad¹, Ribhan Zafira Abdul Rahman¹, Kiyotaka Eguchi², Yoshiyuki Tomiyama² and Farida Izni Abd Rahman¹

¹Department of Electrical and Electronic Engineering, Universiti Putra Malaysia, 43400 UPM, Serdang, Selangor, Malaysia

²Graduate School of Life Science and Systems Engineering, Kyushu Institute of Technology, Hibikino 2-4, Wakamatsu-ku, Kitakyushu, Fukuoka, 808-0196, Japan

ABSTRACT

Biologically inspired robotic hands have important applications in industry and biomedical robotics. The grasping capacity of robotic hands is crucial for a robotic system. This paper presents an experimental study on the finger force and movements of a human hand during the grasping operation in real-time. It focuses on two topics; measuring grasping force using Flexi-force sensors and analysing human hand action during grasping operation. The findings show that lifting required higher forces compared with grasp force in the static phase.

Keywords: Hand grasping, Flexi-force sensors, motion capture systems

INTRODUCTION

Hands are important for almost all activities. Robotic hands are developed with the aim of mimicking the human hand in terms of

dexterity and reliability especially in grasping operations.

In robotic hand sensors are required for the location of the fingertips contact position, measurement of the force applied on the object, and determination of the grasp configuration. Trying to arrive at the best method to measure fingers force is an important aspect of research (Monroy et al., 2009; Ye & Auner, 2003; Kazerooni et al., 2004; Dipietro et al., 2008; Adnan et al., 2012; et al., 2013).

To date, a number of studies have reported the use of force sensor to measure finger force. According to Paredes-Madrid et al., the best

ARTICLE INFO

Article history:

Received: 24 August 2016

Accepted: 02 December 2016

E-mail addresses:

nurfarahelya91@gmail.com (N. F. Elya Saidon),
wada@brain.kyutech.ac.jp (Chikamune Wada),
sanom@upm.edu.my (Siti A. Ahmad),
ribhan@upm.edu.my (Ribhan Zafira Abdul Rahman),
o966006k@mail.kyutech.jp818 (Kiyotaka Eguchi),
ms071121@gmail.com (Yoshiyuki Tomiyama),
iznie8393@yahoo.com (Farida Izni Abd Rahman)

*Corresponding Author

sensor devices for measuring the finger force should have the following list of the characteristics such as repeatability for measuring the high reading, small physical size, light weight, low cost and may be function at a high temperature (Paredes-Madrid et al., 2010). Maeno, et al., 2004; Edussooriya et al., 2008; De et al., 2015) proposed a control strategy to detect slipping off a grasped object using a Flexi-force. However, in order to have a good grasp, not only a force sensation, but also grasping strategies are thought to be important for firm grasping.

According to clinicians, the index finger and thumb are responsible for at least 75% of overall hand functions (Park et al., 2009). There is insufficient evidence in robotic literature on thumb behaviour, despite its important role in grasping operation. To collect information about thumb and fingers during grasping, optoelectronic motion analysis is used (Cordella et al., 2014).

There is little published data on grasping behaviour, this study aims to parameterize the grasping operation in relation to human motion and identify the kinematic parameters and forces related to particular grasping tasks.

BACKGROUND STUDY

Anatomy of Human Hand

The human hand consists of 27 bones, 14 of which are digital bones of the fingers and thumb. Figure 1 shows the skeleton structure of the human hand. A human hand consists of five digits; thumb, index finger, middle finger, ring finger, and little finger. Fingers consist of joints and bones which have similar characteristics, but the thumb has slightly different characteristics (Ungureanu, Stanciu & Menyhardt 2006). Each finger has three links, only the thumb has two joints.

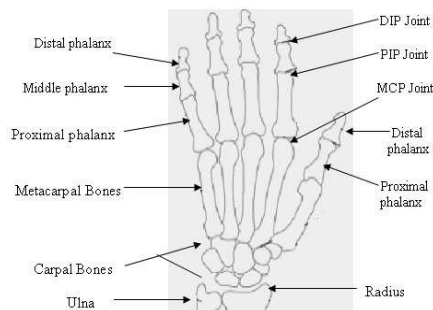

Figure 1. Joints of fingers (Institute for Quality and Efficiency in Health Care, 2012)

The fingers constitute of three interlinking segments: proximal phalange (PP), middle phalange (MP) and distal phalange (DP). The thumb is made up of two segments: proximal phalange (PP) and distal phalange (DP). The first phalanx is connected to the metacarpal bone that constitutes the palm and is connected to the carpal bones. The joints of the fingers are named:

Distal Interphalangeal (DIP), Proximal Interphalangeal (PIP) and Metacarpophalangeal (MCP) joints. The joints for the thumb named: Interphalangeal (IP) and Carpometacarpal (CMC). Joints of the hand vary in the number of degrees of freedom (DOF) they possess. For fingers, Distal Interphalangeal (DIP) and Proximal Interphalangeal (PIP) joints contribute to 1 DOF due to rotational movement while Metacarpophalangeal (MCP) contribute 2 DOF due to adduction-abduction and rotational motion. On the other hand, thumb possesses 5 DOF where Interphalangeal (IP) and Carpometacarpal (CMC) contributes 1 DOF.

Grasping Force

Grasps are defined as a set of contacts on the surface of the object. During grasping, the object is compressed and force generated on the gripper finger to prevent the object from slipping. Many researchers have used piezoresistive Flexi-force to measure finger force (Edussooriya, et al., 2008). This sensor is particularly useful in studying finger force based on the divers advantages; low cost, good sensitivity, simple construction and enhances accuracy.

Motion Analysis

Different kinematic hand models have been proposed using OptiTrack Motion. This system is composed of an infrared (IR) camera, passive ballshaped markers, calibration and analysis software. The ballshaped markers produce X, Y and Z coordinate values are tracked by the infrared cameras and analyze in VENUS 3D software. Using optoelectronic system MOTIVE Software, all marker position must be detected by the cameras (Dutta, 2012; Han & Lee, 2013). If the cameras failed to capture some markers for certain conditions, the cameras were re-positioned.

METHODOLOGY

This project is to analyse human motion and pressure that is applied in grasping a paper cup weighing 200 g and with a radius 26 mm and height of 80 mm. The participant is required to fully extend the fingers and grasp the object with the right hand and lift it to a height of 4cm. Prior to data collection, the subject received an explanation of the experiment. The subject was asked to grasp paper cup using index finger and thumb.

Experimental setup

This project combined two system simultaneously using motion capture system and Flexi-force sensor system. Figure 2 shows the block diagram of the proposed system.

Flexi-force sensors are connected to DAQ hardware and LabVIEW software to acquire sensors signal and facilitate analysis. Motion capture system was used OptiTrack camera to collect data during grasping operations and. Microsoft Visual Studio to program the Arduino UNO and synchronise two signals of the system. The frequency of both systems was set to 100Hz. Lamp act as indicated to compare the signal between both systems.

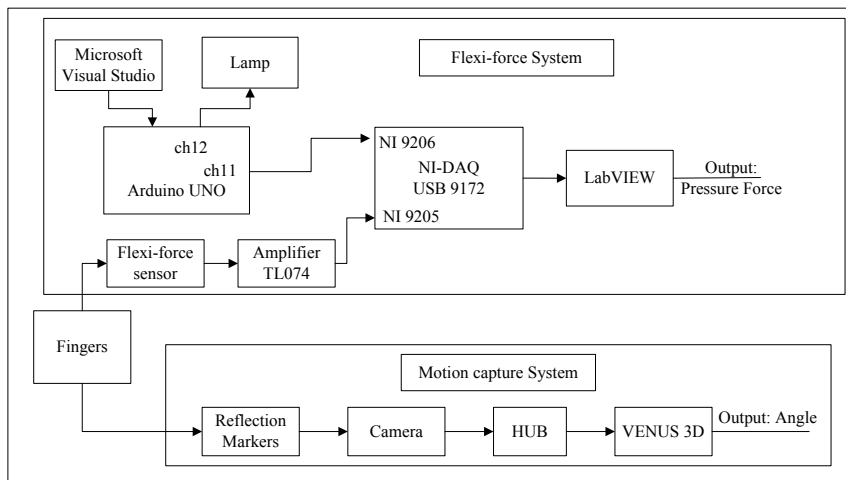

Figure 2. Block diagram of the proposed system)

Flexi-force Sensor

In this paper, the LabVIEW based DAQ system is used to evaluate and measure the pressure force using Flexi-force sensor (0-25)lb/(110N) for real-time robotic hand control. Flexi-force sensors were attached to the fingertips of index finger and thumb as shown in Figure 3.

The Flexi-force sensor sends the signal to DAQ within millivolts range. Hence, sensor is connected to amplifier TL074 and the output voltage is connected DAQ and calibrated using a strain gauge by applying a known uniform weight to the sensing area using different weight. A linear interpolation between the voltage and pressure is plotted and the values were written in LabVIEW to analyse the measurement. Then output voltage from the sensor is converted to the pressure to measure pressure force during grasping.



Figure 3. Flexi-force sensor position

Hand Motion Tracking

In this experiment, six cameras were positioned around the experimental area to detect the marker position and hand motion during grasping operation. We placed twelve reflection markers on the volunteer's right hand and on the object; eight markers were secured at every tip and joint of the index finger and thumb including DIP, PIP, MCP joints with IP and CMC joints of the thumb and four on the object as shown in Figure 4. Eyelash glue is used to fix the small marker. To minimize artefacts due to skin movements or marker occlusion, procedure for positioning markers on the hand has been chosen (Cordella, F. et al., 2014).

The marker position on the cup is able to extract the position of the object with respect to the object radius, height and location of the object during grasping. The motion analysis measures the joints angles by reconstructing the marker position in VENUS 3D software. Joint angles were defined as zero when the finger in fully extended posture.

Data Analysis

A specific program was written in Microsoft Visual Studio to synchronise both systems. Motion capture system and LabVIEW software were run simultaneously to record grasping operation and the lamp as an indicator to synchronise the signals.

For starting configuration, all fingers were fully extended and the thumb was adducted. The marker position was recorded in starting position and during the whole motion until hand grasped the object. After grasping, subject held the object for a while until auditory cue then lifts the cup to 4 cm high and gradually release grasp until the object slipped. The process was repeated four consecutive times and all data were recorded. The joints angle measured for DIP joint of index finger and IP joint for thumb during grasping operation as shown in Figure 4.

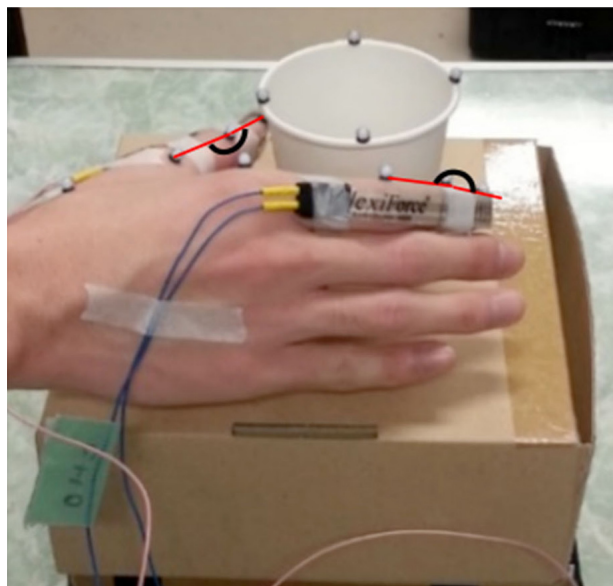

Figure 4. Markers position on volunteer's right hand

RESULTS AND DISCUSSION

To date, this force measurement system and motion tracking has been applied to study the grasp between index finger and thumb. Figure 5 shows the experimental data on sensor and grasping behaviour of the grasp. The angle measured is DIP for index and IP for the thumb as shown in Figure 4. The graph divide the actions of lifting an object and setting it back down into seven states as shown in Table 1.

Figure 5 shows the sub-phases of movement which identified due to significant variations produced by the motion capture and measuring system (T1-T7); reaching, grasping, lifting, stable, slipping, release and original position. Using both systems allows the identification of variables which relevance to description of the movement.

Table 1
Hand motion states

State	T1	T2	T3	T4	T5	T6	T7
Action	Reach	Grasp	Lift	Hold	Slip	Release	Original hand position

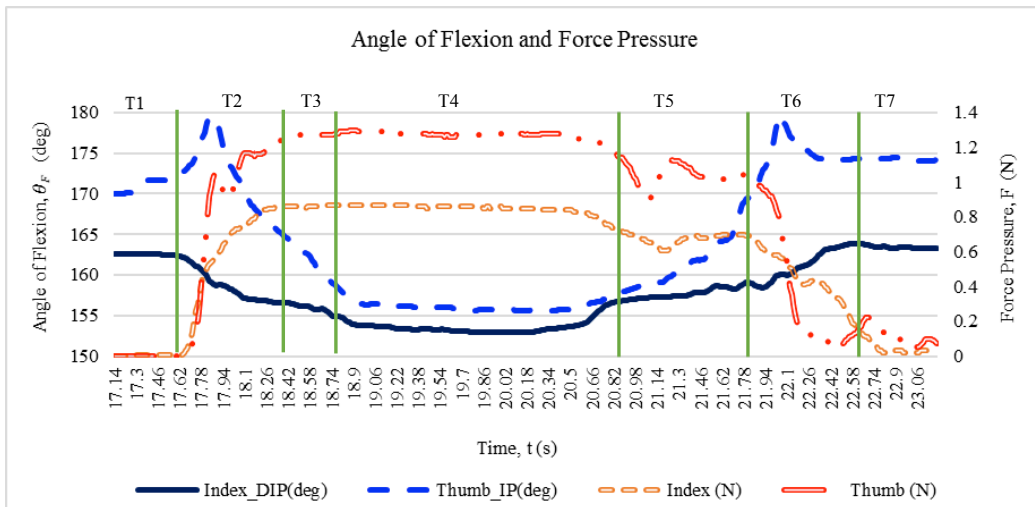

Figure 5. Angle of flexion and grasping force

The grasping force during lifting, stable and slippery states were measured and shown in Table 2.

An initial objective of the project was to identify the relationship between the grasping operation, the sensory system and human motion. Figure 5 presents the data while performing the grasp based on flexion angle of index finger and thumb and grasping force. Based on the results, the correlation between angle of flexion and force measurement is established. During

the grasping and lifting of a cup between the fingertips, the subject manipulated the cup for stable grasping and grasp force simultaneously caused small vibration in the data.

Another important finding was the force required to lift, grasp and release as shown in Table 2 shows during the first 2 s of contact with the cup are small compared to the forces needed to lift the cup off the table. The force required to lift the cup builds up gradually from the time of initial contact. The results confirm that lifting requires higher forces than grasping in the static phase due to gravitational force needed to lift an object. However, these results were not very encouraging because of the object's weight and the subject's limitation.

Table 2
Descriptive analysis of the forces

	Contact Force, F_c (N) Mean \pm SD	Lifting Force, F_L (N) Mean \pm SD	Stable Force, F (N) Mean \pm SD	Slippery Force, F_s (N) Mean \pm SD
Thumb	0.800 \pm 0.484	1.279 \pm 0.009	1.266 \pm 0.016	1.064 \pm 0.078
Index	0.557 \pm 0.312	0.862 \pm 0.007	0.837 \pm 0.013	0.688 \pm 0.041

CONCLUSION

This paper analyses index finger and thumb motion during grasping. Results indicate lifting requires more force than stable force. This research extends our knowledge of force required to model robot hand controller system.

ACKNOWLEDGEMENT

This work is supported by the East Policy 2.0 Grants Programme (LEP 2.0).

REFERENCES

- Adnan, N. H., Khairunizam, W. A. N., & Shahrman, A. B. (2012). Accurate measurement of the force sensor for intermediate and proximal phalanges of index finger. *International Journal of Computer Applications*, 45(15), 59-65.
- Adnan, N. H., Wan, K., Shahrman, A., Za'ba, S. K., Desa, H., & Aziz, M. A. A. (2012). The development of a low cost data glove by using flexible bend sensor for resistive interfaces. In *2nd Int. Malaysia-Ireland Joint Symposium on Engineering, Science and Business*.
- Ali, M. H., Khairunizam, W. A. N., Adnan, N. H., Seah, Y. C., Bakar, J. A. A., & Razlan, Z. M. (2013). Analysis of finger movement by using motion information from GloveMAP and motion capture system. *International Journal of Mechanical and Mechatronics Engineering*, 13(3).
- Cordella, F., Zollo, L., Salerno, A., Accoto, D., Guglielmelli, E., & Siciliano, B. (2014). Human hand motion analysis and synthesis of optimal power grasps for a robotic hand. *International Journal of Advanced Robotic Systems*, 11(37), 1-14.
- De Maria, G., Falco, P., Natale, C., & Pirozzi, S. (2015, May). Integrated force/tactile sensing: The enabling technology for slipping detection and avoidance. In *2015 IEEE International Conference on Robotics and Automation (ICRA)* (pp. 3883-3889). IEEE.

N. F. Elya Saidon, Chikamune Wada, Siti A. Ahmad, Ribhan Zafira Abdul Rahman, Kiyotaka Eguchi,
Yoshiyuki Tomiyama and Farida Izni Abd Rahman

- Dipietro, L., Sabatini, A. M., & Dario, P. (2008). A survey of glove-based systems and their applications. *IEEE Transactions on Systems, Man, and Cybernetics Part C: Applications and Reviews*, 38(4), 461-482.
- Dutta, T. (2012). Evaluation of the kinect™ sensor for 3-D kinematic measurement in the workplace. *Journal of Applied Ergonomics*, 43(4), 645-649.
- Edussooriya, C. U. S., Hapuachchi, H. S. S., Rajiv, D., Ranasinghe, R. A. H., & Munasinghe, S. R. (2008). Analysis of grasping and slip detection of the human hand. In *International Conference on Information and Automation for Sustainability* (pp. 261-266).
- Han, S., & Lee, S. (2013). A vision-based motion capture and recognition framework for behavior-based safety management. *Journal of Automation in Construction*, 35, 131-141.
- Kazerooni, H., Fairbanks, D., Chen, A., & Shin, G. (2004, May). The magic glove. In *Robotics and Automation, 2004. Proceedings. ICRA'04. 2004 IEEE International Conference on* (Vol. 1, pp. 757-763). IEEE.
- Maeno, T., Kawamura, T., & Cheng, S. C. (2004). Friction estimation by pressing an elastic finger-shaped sensor against a surface. *IEEE Transactions on Robotics and Automation*, 20(2), 222-228.
- Monroy, M., Ferre, M., Barrio, J., Eslava, V., & Galiana, I. (2009, April). Sensorized thimble for haptics applications. In *2009 IEEE International Conference on Mechatronics*.
- Paredes-Madrid, L., Torruella, P., Solache, P., Galiana, I., & de Santos, P. G. (2010, May). Accurate modeling of low-cost piezoresistive force sensors for haptic interfaces. In *Robotics and Automation (ICRA), 2010 IEEE International Conference on* (pp. 1828-1833). IEEE.
- Park, W. I., Kwon, S. C., Lee, H. D., & Kim, J. (2009, June). Thumb-tip force estimation from sEMG and a musculoskeletal model for real-time finger prosthesis. In *2009 IEEE International Conference on Rehabilitation Robotics* (pp. 305-310). IEEE.
- Ungureanu, L., Stanciu, A., & Menyhardt, K. (2006, October). Actuating a human hand prosthesis: model study. In *2nd WSEAS International Conference on Dynamical Systems and Control, Bucharest Romania*.
- Ye, Z., & Auner, G. (2003, June). Haptic interface prototype for feedback control on robotic integration of smart sensors. In *Control Applications, 2003. CCA 2003. Proceedings of 2003 IEEE Conference on* (Vol. 2, pp. 995-1000). IEEE.